

WARRANTY

All Legend Air Suspension System™ parts are guaranteed to the original purchaser to be free of manufacturing defects and workmanship. Merchandise that fails to conform to these conditions will be repaired or replaced at Legend Air Suspension Systems™ option if the parts are returned to us by the purchaser. Warranty coverage is limited lifetime.

In the event warranty service is required, the original purchaser must call or write Legend Air Suspension Systems™ immediately with the problem. Some problems can be rectified by a telephone call and need no further course of action.

A part that is suspect of being defective must not be replaced by a Dealer without prior authorization from Legend Air Suspension Systems™. If it is deemed necessary for Legend Air Suspension Systems™ to make an evaluation to determine whether the part was defective, a return authorization number must be obtained from Legend Air Suspension Systems™. The parts must be packaged properly so as to not cause further damage and be returned prepaid to Legend Air Suspension Systems™ with a copy of the original invoice of purchase and a detailed letter outlining the nature of the problem, how the part was used and the circumstances at the time of failure. If after an evaluation has been made by Legend Air Suspension Systems™ and the part was found to be defective, repair will be made at Legend Air Suspension Systems™ discretion.

ADDITIONAL WARRANTY PROVISIONS

- (1) Legend Air Suspension Systems™ shall have no obligation in the event a Legend Air Suspension Systems™ part is modified by any other person or organization.
- (2) Legend Air Suspension Systems™ shall have no obligation if a Legend Air Suspension Systems™ part becomes defective in whole or in part as a result of improper installation, improper maintenance, improper use, abnormal operation, or any other misuse or mistreatment of the Legend Air Suspension Systems™ part.

(3) Legend Air Suspension Systems™ shall not be liable for any consequential or incidental damages resulting from the failure of a Legend Air Suspension Systems™ part, the breach of any warranties, the failure to deliver, delay in delivery in non-conforming condition, or for any other breach of contract of duty between Legend Air Suspension Systems™ and a customer.

(4) Parts are designed for use on Harley-Davidson Tri Glide™ models. Legend Air Suspension Systems™ shall have no warranty or liability obligation if a Legend Air Suspension Systems™ part is used in any other application. Vehicles used in competition or off road are exempt from all warranties. Any transmission bolts or motorcycle parts touching airride from top down may cause damage to suspension and will void the warranty.

(5) All warranty items will require a serial number off the airride, or the original purchase invoice.

Legend Air Suspension Systems™ assumes no responsibility for damage or injuries which may result from the use or installation of its products, whether or not properly installed or used. All parts sold or manufactured by Legend Air Suspension Systems™ are warranted against all manufacture defects or workmanship defects. Should a product we manufacture be defective, it must be returned to Legend Air Suspension Systems™. All returns must be authorized in advance with RA#. Freight must be prepaid by customer. If our product is found to be defective, it will be repaired free of charge or exchanged at Legend Air Suspension Systems™ discretion. Repairs or exchanges will not be issued if merchandise has been damaged, abused or modified. Any disagreement which may arise out of this agreement shall be submitted to arbitration and shall be enforceable under the laws of the State of South Dakota. Judgement on the award shall be entered into by the said court, and the decision of the arbitrator shall be a condition precedent to legal rights. The parties shall submit disputed matters under the Rules of the American Arbitration Association and the losing party shall pay both parties' attorneys' fees and costs.



MADE IN THE USA



legendsuspensions.com



INSTALLATION GUIDE

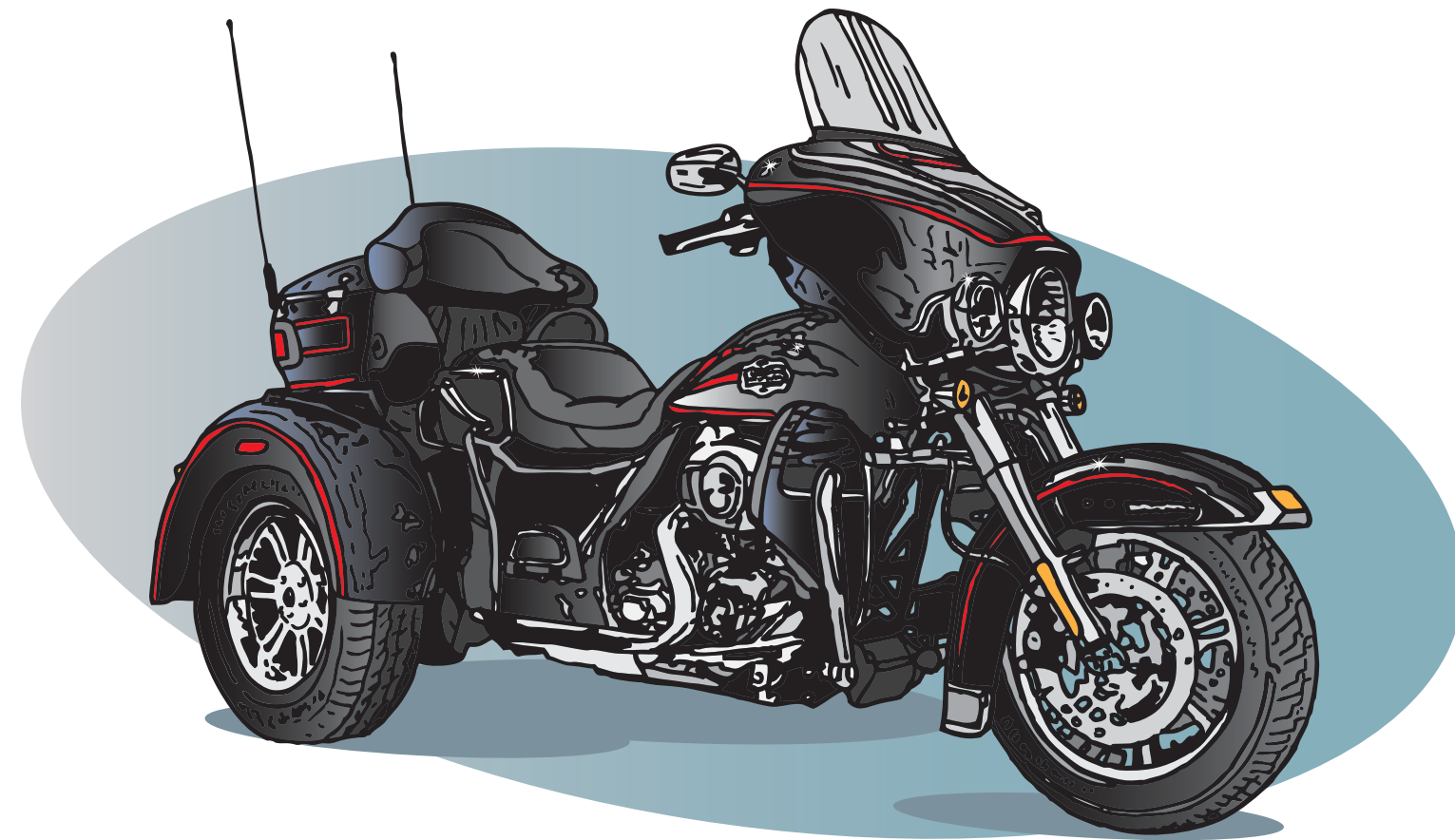



PROPERLY SUPPORT YOUR TRIKE PRIOR TO AIR SUSPENSION INSTALLATION!



1

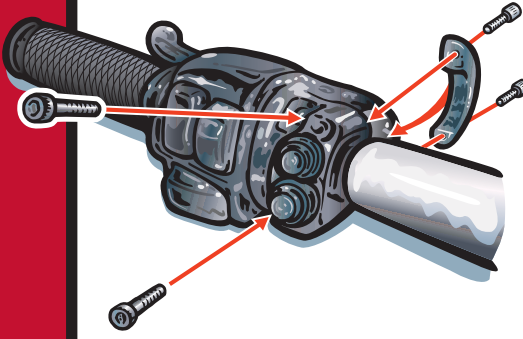

STEP ONE: HANDLEBAR SWITCH

- A. REMOVE STOCK CLUTCH CLAMP.
- B. RE-USING STOCK HARDWARE, INSTALL LEGEND HANDLEBAR SWITCH HOUSING MAKING SURE NOT TO PINCH WIRES.
- C. ROUTE WIRES DOWN THE HANDLEBAR, UNDER THE GAS TANK, AND TO THE BATTERY COMPARTMENT.

NOTE: ON TRI GLIDE WITH ELECTRIC REVERSE, INSTALL SWITCH HOUSING ON RIGHT SIDE. IN STEP 3, PLUG THE YELLOW HANDLEBAR SWITCH WIRE INTO THE GREEN WIRE FROM RELAY AND THE GREEN HANDLEBAR SWITCH WIRE INTO THE YELLOW WIRE FROM COMPRESSOR.

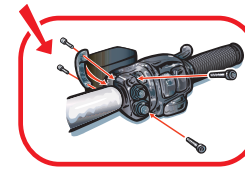

2

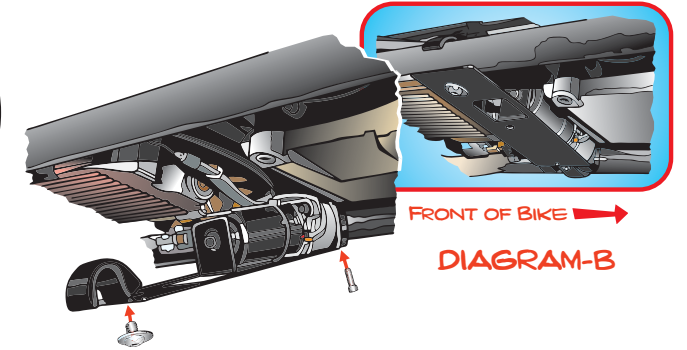

FRONT OF BIKE →

DIAGRAM-B

STEP TWO: COMPRESSOR MOUNT

- A. MOUNT COMPRESSOR BRACKET ASSEMBLY ONTO THE BOTTOM FRAME RAILS BETWEEN MOTOR AND TRANSMISSION CASE AS SHOWN IN **DIAGRAM-B**. APPLY BLUE THREAD LOCKER TO HARDWARE, USING 1/4-20 X 1" CAP SCREW TO CLAMP THE LEFT SIDE AND 1/4-20 X 1/2" BUTTON HEAD SCREW TO CLAMP THE RIGHT SIDE.
- B. ROUTE WIRES AND AIR TUBING ALONG RIGHT SIDE FRAME RAIL AS SHOWN IN **DIAGRAM-C**, UP AND BEHIND THE RIGHT SIDE COVER PANEL.

DIAGRAM-C

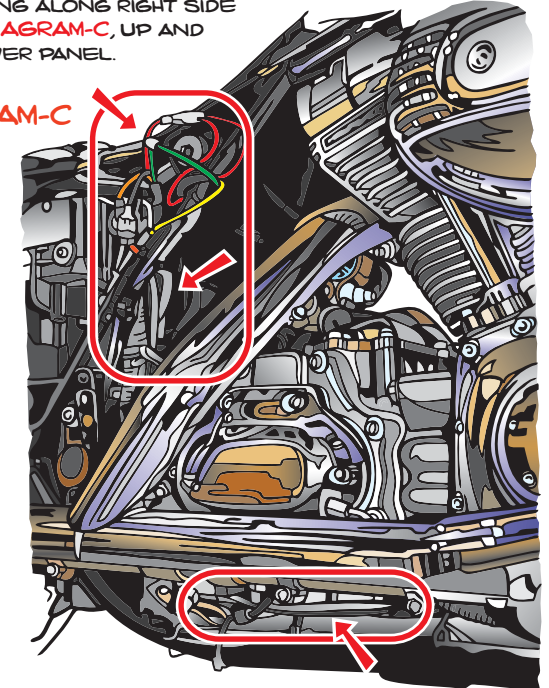

5

STEP FIVE: OPERATION

- A. INSTALL FUSE IN FUSE HOLDER AND PUSH TOP BUTTON TO ADD AIR TO THE SYSTEM.
- B. PUSH BOTTOM BUTTON TO RELEASE AIR AND MAKE SURE SYSTEM IS WORKING PROPERLY.
- C. CHECK FENDER TO TIRE CLEARANCE TO MAKE SURE NOTHING IS RUBBING.
- D. RE-INSTALL IGNITION MODULE COVER, AND SEAT.

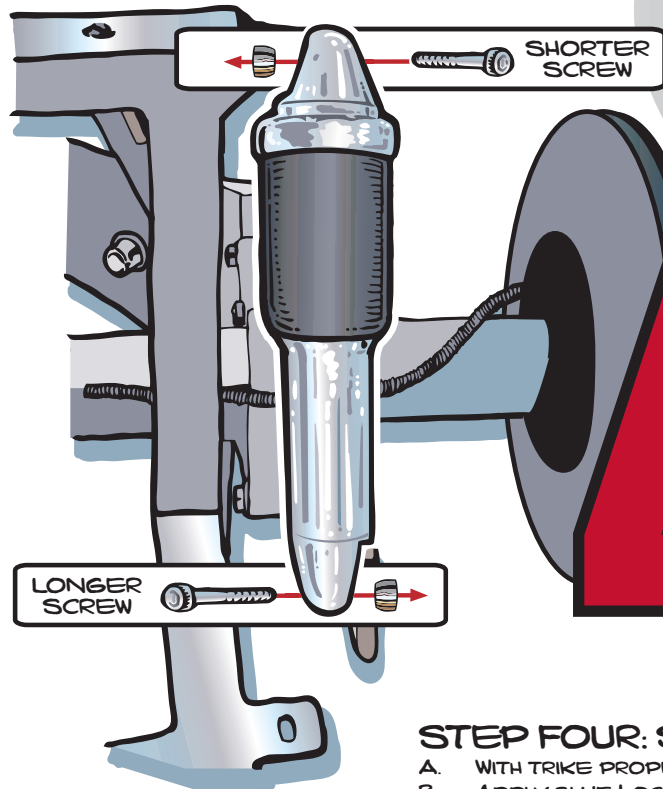
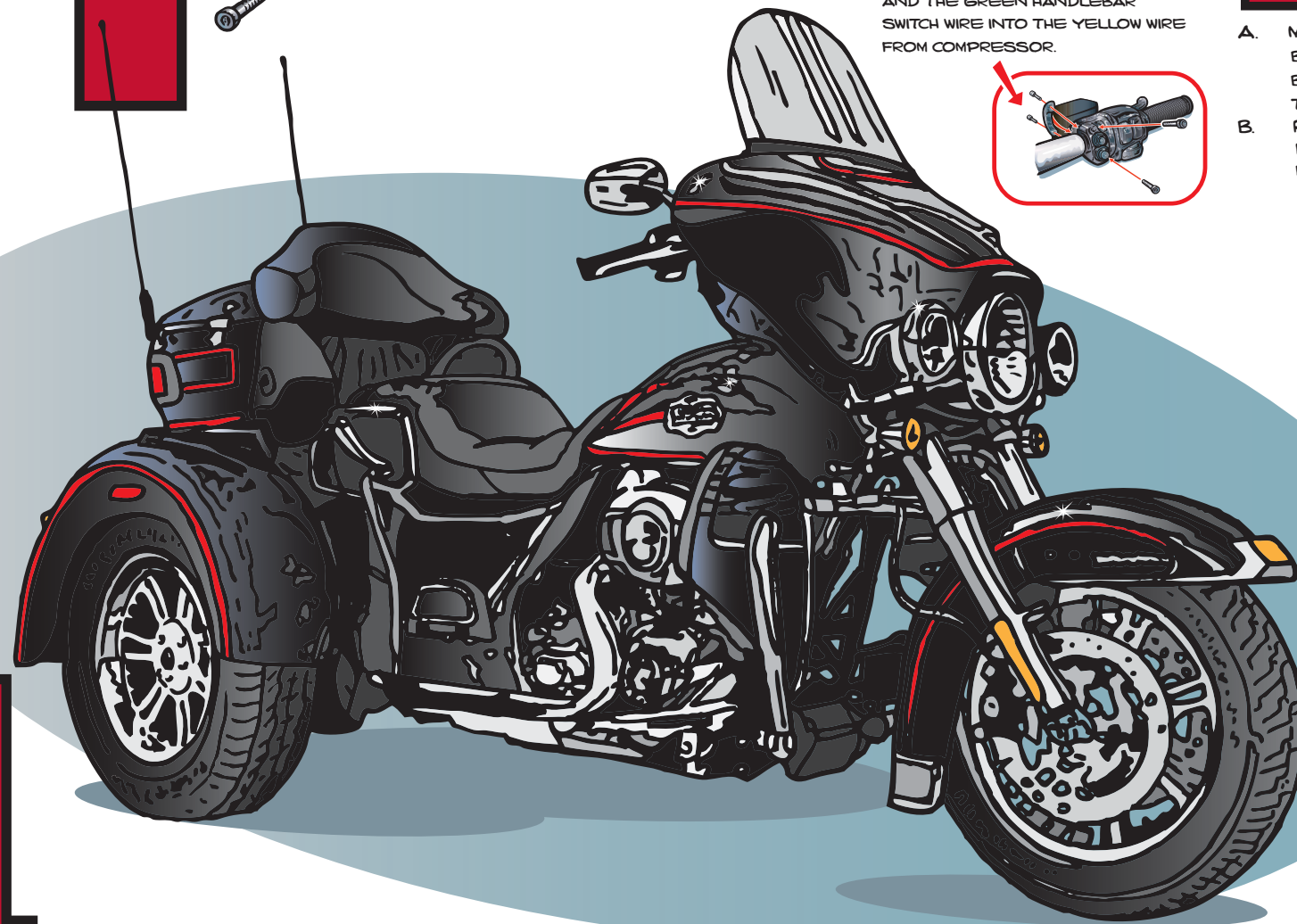

STEP FOUR: SHOCKS

- A. WITH TRIKE PROPERLY SUPPORTED ON JACK AND JACK STANDS, REMOVE STOCK SHOCKS.
- B. APPLY BLUE LOC-TITE™ TO FASTENERS AND INSTALL LEGEND AIR SUSPENSION™ GIVING ATTENTION TO SPACER AND BOLT ORIENTATION. **TIP:** LOWER SWINGARM TO INSTALL LOWER SHOCK MOUNTS FIRST.
- C. RUN AIR LINE FROM SHOCKS TO THE BATTERY COMPARTMENT. USING SUPPLIED "Y" FITTING CONNECT THE AIR LINE FROM THE SHOCKS TO THE AIR LINE FROM THE COMPRESSOR.
- D. LOWER BIKE ONTO REAR TIRE SO SHOCKS ARE FULLY COMPRESSED BEFORE INFLATING SHOCKS.

3

STEP THREE: WIRING

- A. MOUNT RELAY WITH ATTACHED VELCRO IN THE BATTERY COMPARTMENT, AND ROUTE THE WIRES TO BEHIND THE RIGHT SIDE COVER PANEL.
- B. CONNECT WIRES FROM COMPRESSOR, HANDLEBAR SWITCH, AND RELAY HARNESS USING COLOR CODED WIRING.
- C. CONNECT POSITIVE AND NEGATIVE CABLES TO BATTERY.

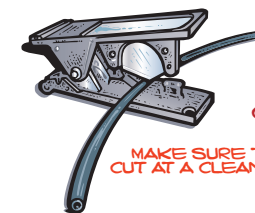

MAKE SURE TUBING IS CUT AT A CLEAN 90° ANGLE

TOOLS NEEDED...

