

WARRANTY

All Legend Air Suspension System™ parts are guaranteed to the original purchaser to be free of manufacturing defects and workmanship. Merchandise that fails to conform to these conditions will be repaired or replaced at Legend Air Suspension Systems™ option if the parts are returned to us by the purchaser. Warranty coverage is limited lifetime.

In the event warranty service is required, the original purchaser must call or write Legend Air Suspension Systems™ immediately with the problem. Some problems can be rectified by a telephone call and need no further course of action.

A part that is suspect of being defective must not be replaced by a Dealer without prior authorization from Legend Air Suspension Systems™. If it is deemed necessary for Legend Air Suspension Systems™ to make an evaluation to determine whether the part was defective, a return authorization number must be obtained from Legend Air Suspension Systems™. The parts must be packaged properly so as to not cause further damage and be returned prepaid to Legend Air Suspension Systems™ with a copy of the original invoice of purchase and a detailed letter outlining the nature of the problem, how the part was used and the circumstances at the time of failure. If after an evaluation has been made by Legend Air Suspension Systems™ and the part was found to be defective, repair will be made at Legend Air Suspension Systems™ discretion.

ADDITIONAL WARRANTY PROVISIONS

- (1) Legend Air Suspension Systems™ shall have no obligation in the event a Legend Air Suspension Systems™ part is modified by any other person or organization.
- (2) Legend Air Suspension Systems™ shall have no obligation if a Legend Air Suspension Systems™ part becomes defective in whole or in part as a result of improper installation, improper maintenance, improper use, abnormal operation, or any other misuse or mistreatment of the Legend Air Suspension Systems™ part.

(3) Legend Air Suspension Systems™ shall not be liable for any consequential or incidental damages resulting from the failure of a Legend Air Suspension Systems™ part, the breach of any warranties, the failure to deliver, delay in delivery in non-conforming condition, or for any other breach of contract of duty between Legend Air Suspension Systems™ and a customer.

(4) Parts are designed for use on the Kubota RTV™ 900 & 1100. Legend Air Suspension Systems™ shall have no warranty or liability obligation if a Legend Air Suspension Systems™ part is used in any other application. Vehicles used in competition or racing are exempt from all warranties. Any bolts or parts touching airride from top down may cause damage to suspension and will void the warranty.

(5) All warranty items will require a serial number off the airride, or the original purchase invoice.

Legend Air Suspension Systems™ assumes no responsibility for damage or injuries which may result from the use or installation of its products, whether or not properly installed or used. All parts sold or manufactured by Legend Air Suspension Systems™ are warranted against all manufacture defects or workmanship defects. Should a product we manufacture be defective, it must be returned to Legend Air Suspension Systems™. All returns must be authorized in advance with RA#. Freight must be prepaid by customer. If our product is found to be defective, it will be repaired free of charge or exchanged at Legend Air Suspension Systems™ discretion. Repairs or exchanges will not be issued if merchandise has been damaged, abused or modified. Any disagreement which may arise out of this agreement shall be submitted to arbitration and shall be enforceable under the laws of the State of South Dakota. Judgement on the award shall be entered into by the said court, and the decision of the arbitrator shall be a condition precedent to legal rights. The parties shall submit disputed matters under the Rules of the American Arbitration Association and the losing party shall pay both parties' attorneys' fees and costs.



MADE IN THE USA



www.legendsuspensions.com



INSTALLATION GUIDE



For Technical & Warranty Information: 605.720.4202 or warranty@legendsuspensions.com

KUBOTA™
RTV 900 & 1100



PROPERLY SUPPORT YOUR UTV PRIOR TO AIR SUSPENSION INSTALLATION!



1

STEP ONE: MOUNT AIR COMPRESSOR, SOLENOID & TERMINAL BLOCK UNDER RIGHT SIDE HOOD AREA

- A. USE SOLENOID AND TERMINAL BLOCK AS TEMPLATE TO WHERE TO DRILL THE MOUNTING HOLES, AND THE SUPPLIED TEMPLATE FOR THE COMPRESSOR.
- B. AIR COMPRESSOR; USE THREE M6 SOCKET HEAD BOLTS WITH WASHERS.
- C. SOLENOID; USE TWO 1/4" SOCKET HEAD BOLTS WITH WASHERS.
- C. TERMINAL BLOCK; USE TWO 10-32 SOCKET HEAD BOLTS WITH WASHERS AND LOCK NUTS OR SELF TAPPING SCREWS.



NOTE: MAKE SURE YOU MOUNT THE COMPONENTS WITHIN THE WIRE'S REACH.

STEP TWO: WIRING

- A. SWITCH(S) AND PRESSURE GAUGE(S) CAN BE INSTALLED UTILIZING SUPPLIED BRACKET(S) OR MOUNTED DIRECTLY INTO THE DASH OR CONSOLE OF THE VEHICLE. MOUNTING LOCATION IS PERSONAL PREFERENCE.
 - I. USE TWO 1/4"-2.0X1/2" BOLTS, WASHERS AND LOCK NUTS TO MOUNT EACH BRACKET.
 - II. USE PROVIDED TEMPLATES TO MARK AND CUT OUT FOR DASH AND CONSOLE MOUNTING.
- B. CONNECT WIRES TO THE MATCHING COLOR CODES ON THE TERMINAL BLOCK AND PUSH TO CONNECT FITTINGS.
- C. CONNECT **BLACK (-)** WIRE TO NEGATIVE BATTERY POST AND **RED** WIRE TO THE POSITIVE (+) BATTERY POST.
- D. INSTALL FUSE IN FUSE HOLDER (SEE INSERT: DIAGRAM-D)

2

SEE INSERT FOR MORE DETAILS

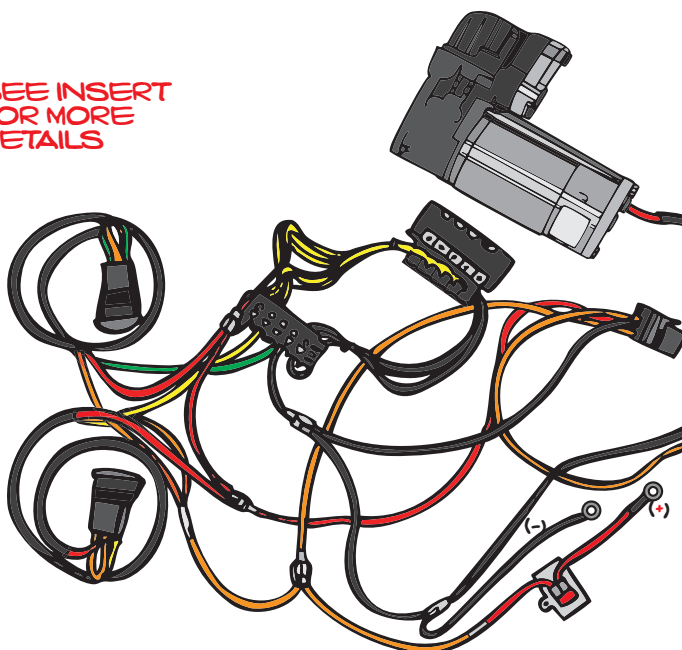

NOTE: PROFESSIONAL INSTALLATION HIGHLY RECOMMENDED!

3

STEP THREE: ROUTE AIR TUBING

- A. CAREFULLY CUT AIR TUBING AT 90° WITH A SHARP BLADE! (SEE INSERT: DIAGRAM-C)
- B. ROUTE AIR TUBING FROM EACH SHOCK TO THE SOLENOID BLOCK. A REAR SHOCK CONNECTS TO EACH R-OUTLET ON THE SOLENOID BLOCK, AND A FRONT SHOCK CONNECTS TO EACH F-OUTLET ON THE SOLENOID BLOCK. RUN THE AIR TUBING FROM THE AIR COMPRESSOR OUTLET TO THE FITTING ON THE SIDE OF THE SOLENOID BLOCK. (SEE INSERT: DIAGRAM-F)
- C. SECURE AIR TUBING USING ZIP TIES TO AVOID POTENTIAL HAZARDS LIKE EXHAUST, DRIVE SHAFT AND OTHER MOVABLE PARTS.
- D. CONNECT THE FRONT GAUGE BY TAPPING INTO THE TUBING GOING TO ONE OF THE FRONT SHOCKS USING SUPPLIED Y-FITTING. TAP INTO ONE OF THE REAR SHOCKS TUBING TO CONNECT THE REAR GAUGE (SEE INSERT: DIAGRAM F).

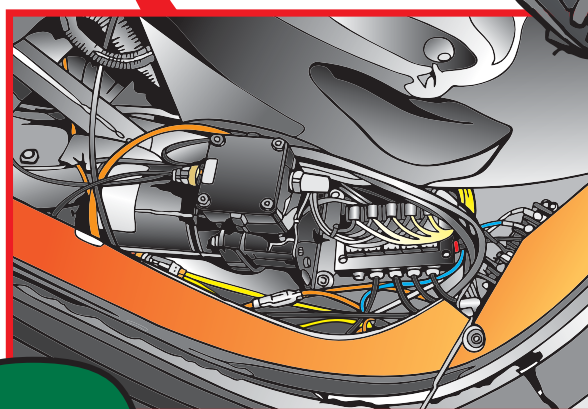

NOTE: MOUNT AIR COMPRESSOR UNDER HOOD BEHIND RIGHT HEADLIGHT (PASSENGER SIDE).

TOP VIEW

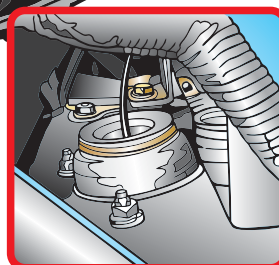

NOTE: REUSE KUBOTA COMPONENTS FROM STOCK STRUT ASSEMBLY

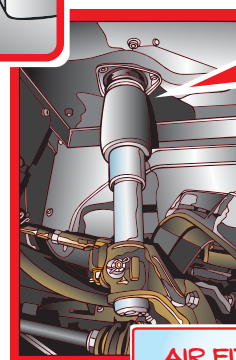

AIR FITTING

5

STEP FOUR: MOUNT SHOCKS

- A. SAFELY LIFT THE VEHICLE OFF THE GROUND TO WHERE SHOCKS ARE FULLY EXTENDED, AND SECURE VEHICLE USING JACK STANDS.
- B. REMOVE THE WHEELS AND ALL THE STOCK SHOCKS.
- C. INSTALL LEGEND AIR SHOCKS. REAR: BY REUSING OE HARDWARE AND BLUE LOCTITE. PAY ATTENTION TO ILLUSTRATIONS OF SUPPLIED SPACER'S ORIENTATIONS. FRONT: USING SMALL AMOUNT OF BLUE LOCTITE INSTALL AIR FITTING. ASSEMBLE TOP OF LEGEND SHOCK STRUT REUSING KUBOTA COMPONENTS FROM THE STOCK STRUT AS SHOWN IN THE FRONT SHOCK DIAGRAM.
- D. REMOVE THE PLUG IN THE SHOCK-FITTINGS, AND INSERT THE AIR TUBING ROUTED TO EACH SHOCK. (SEE INSERT: DIAGRAM-B)
- E. USING THE SWITCH(S), ADD AIR TO THE SHOCKS UNTIL THE AIR BAGS ARE FIRM (APPROXIMATELY 40 PSI).
- F. MOUNT THE WHEELS.
- G. SAFELY LOWER THE VEHICLE OFF THE JACK STANDS ONTO THE FLOOR.
- H. COMPLETELY DEFLATE BOTH FRONT AND REAR SHOCKS.
- I. INSPECT THE AIR BAGS, AND MAKE SURE THEY ROLL UNIFORMLY OVER THE SHOCK BODY.

4

FRONT SHOCKS

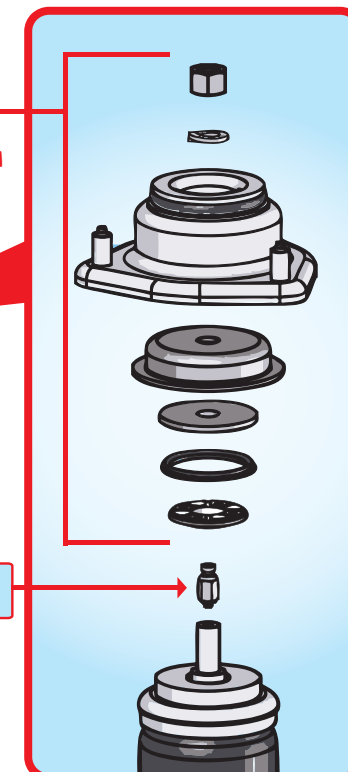

REAR SHOCKS

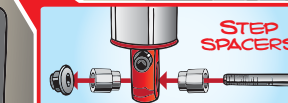
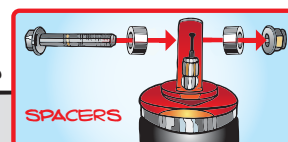
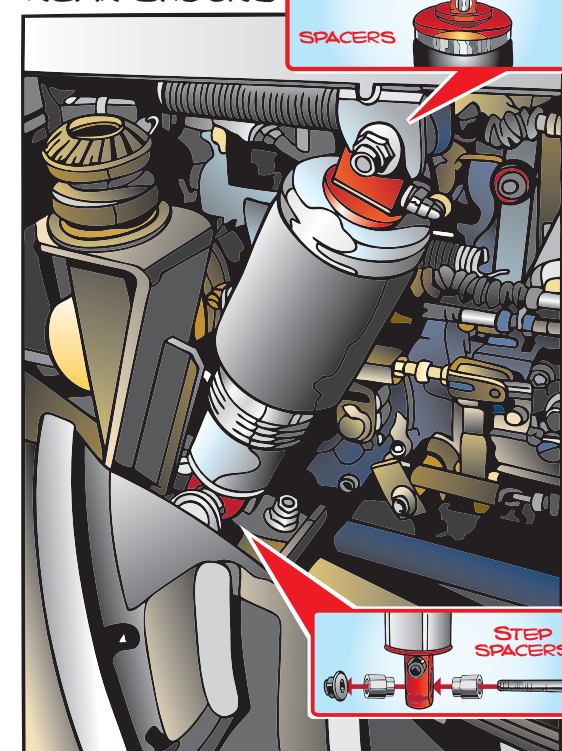

STEP FIVE: INITIAL RIDE HEIGHT SETTING

- A. ADD AIR TO FRONT AND REAR SHOCKS SEPARATELY UNTIL THE VEHICLE STOPS RISING. **DO NOT INFLATE FRONT AND REAR AT THE SAME TIME.**
- B. GO RIDING AND FINE TUNE TO YOUR PERSONAL PREFERENCE.